

THIS DRAWING IS UNPUBLISHED. RELEASED FOR PUBLICATION  
 © COPYRIGHT BY TYCO ELECTRONICS CORPORATION. ALL INTERNATIONAL RIGHTS RESERVED.

LOC	DIST	REVISIONS					
AF	50	P	LTR	DESCRIPTION	DATE	DWN	APVD
		G		REVISED PER ECR-10-006099	07JUL10	HMR	PD

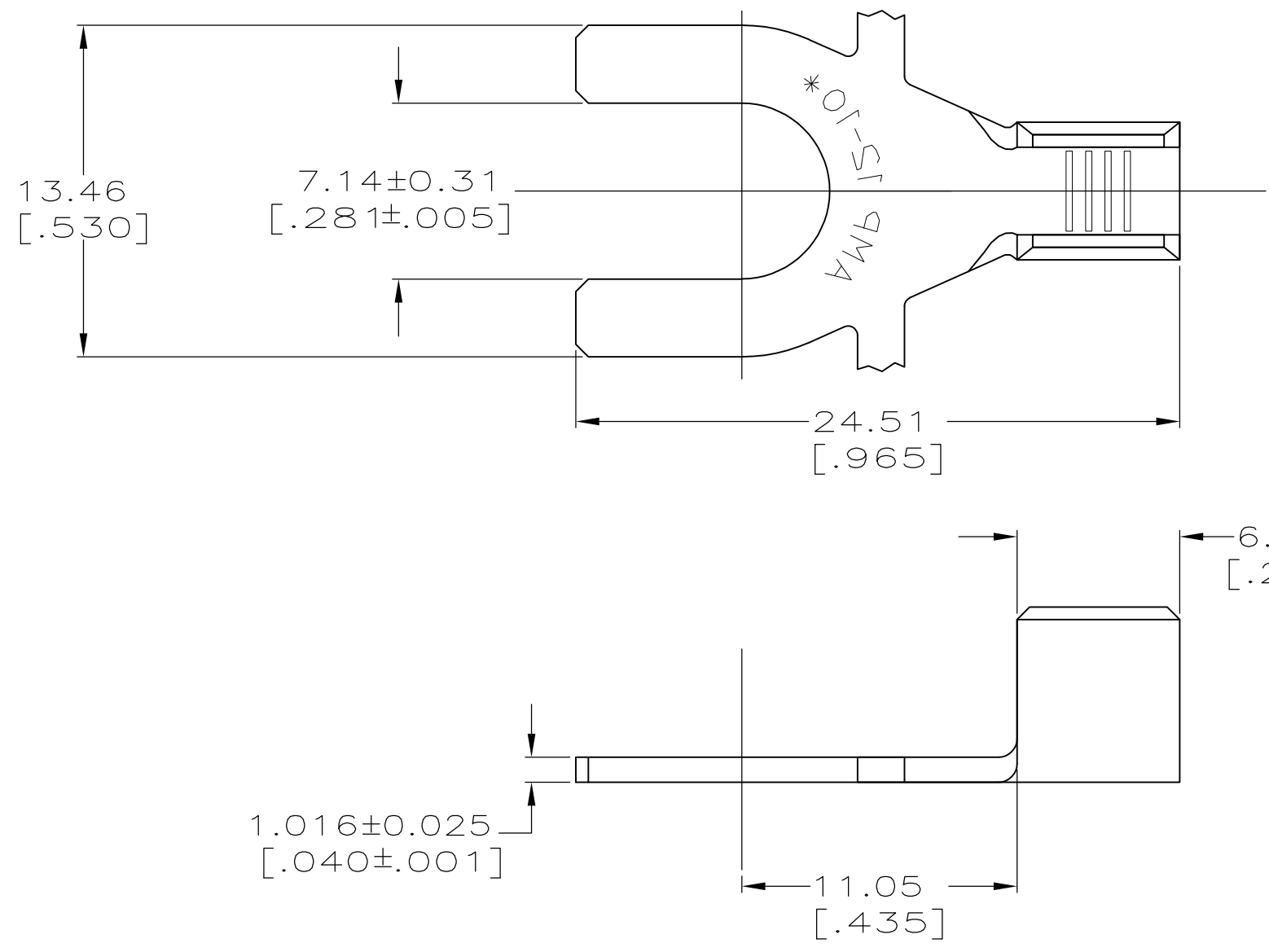

1. CONTINUOUS STRIP ON REELS

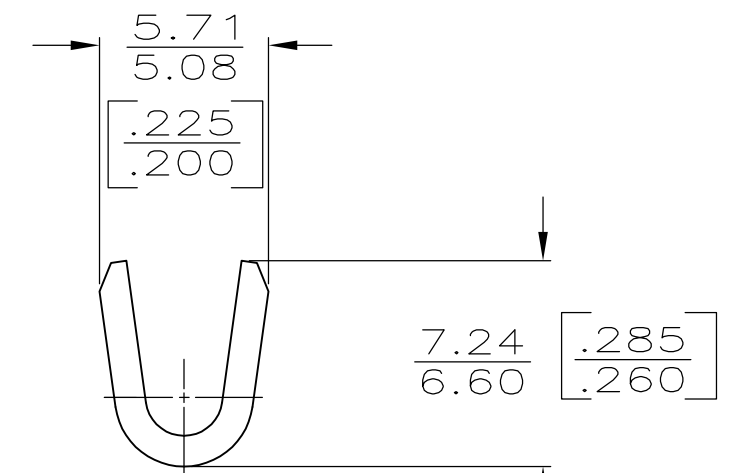

3.0mm <sup>2</sup> - 6.0mm <sup>2</sup> [12-10] AWG	60313-2
WIRE RANGE	PART NO

F	4.57 [.180]	3.78 [149]	6.0mm <sup>2</sup> [10]
		3.40 [134]	3.0mm <sup>2</sup> [12]
TYPE	WIDTH	±0.051 [E.002] HEIGHT	WIRE
WIRE BARREL CRIMP			

THIS DRAWING IS A CONTROLLED DOCUMENT.	
DIMENSIONS: mm [INCHES]	TOLERANCES UNLESS OTHERWISE SPECIFIED:
	0 PLC ± -
	1 PLC ± -
	2 PLC ± -
	3 PLC ± 0.38 [015]
4 PLC ± -	± -
ANGLES	
MATERIAL #1 HARD BRASS	FINISH TIN

DWN P FORTNEY	12/1/89	 Tyco Electronics Corporation Harrisburg, PA 17105-3608	NAME		
CHK MS FEHER	12/1/89		SPADE		
APVD G YETTER	12/1/89		NAME		
PRODUCT SPEC		SIZE	CAGE CODE	DRAWING NO	RESTRICTED TO
APPLICATION SPEC		A3	00779	C-60313	-
WEIGHT	-	CUSTOMER DRAWING		SCALE	4:1
		SHEET		1 OF 1	REV
					G